

# NATIONAL INSTITUTE OF TECHNOLOGY KARNATAKA, SURATHKAL

DEPARTMENT OF CENTRAL RESEARCH FACILITY  
POST SRINIVASNAGAR, MANGALORE – 575 025 (D K)

Phone: (0824) 2474000.  
E- mail: info@nitk.ac.in

Fax: (0824) 2474033  
Website: http://www.nitk.ac.in



## TENDER DOCUMENT

Tender Notification No: NITK/CRF/Fur3-Tables/04

Date: 15/12/2020

Name of Goods	Office Tables
Estimated amount put to Tender	₹ 5,00,000/- (Including GST)
Time for Supply of item	1 month
Bid Document Download Start Date	15/12/2020 @ 5:30 p.m.
Clarification Start Date	NA
Clarification End Date	NA
Online Bid Submission Start Date	15/12/2020 @ 5:30 p.m.
Online Bid Submission End Date	05/01/2021, @ 3.00 p.m.
Address for Submission of Tender	<a href="https://eprocure.gov.in/">https://eprocure.gov.in/</a>
Opening date of technical bid	06/01/2021 @ 3.30 p.m.
Contact Details of Buyer	Dr. Keyur Raval, 9342421444, <a href="mailto:keyurnraval@nitk.edu.in">keyurnraval@nitk.edu.in</a> 9632493401, office.crf@nitk.edu.in



# NATIONAL INSTITUTE OF TECHNOLOGY KARNATAKA, SURATHKAL

POST SRINIVASNAGAR, MANGALURU – 575 025

(Institute Of National Importance Under Ministry of Education, Govt. of India)

Phone: (0824) 2474 000.

Fax: (0824) 2474 033/ 2474 039

Email: registrar@nitk.ac.in

Website: <http://www.nitk.ac.in>

Tender Notification No: NITK/CRF/PCTCCC/SHPB/04

Date: 15/12/2020

## **NOTICE INVITING e-TENDER (e-NIT)**

The National Institute of Technology Karnataka, Surathkal (in short – NITK, Surathkal) is an Institute Of National Importance Under Ministry of Education, Govt of India imparting Technical Education and engaged in Research Activities.

Online Tender (<https://eprocure.gov.in/>) is invited for the following items in **two cover system** (i.e., Technical bid and financial bid) subject to the following terms and conditions, from the reputed manufacturers or it's authorized dealers so as to reach this office on or before scheduled date and time. The tender (Technical bid) will be opened online on the due date as mentioned. Bidders can verify their bid status through online portal <https://eprocure.gov.in/>. The financial bid of only such bidders whose technical bid is accepted shall be opened on the same day or later pre-informed date.

<b>Name of Goods</b>	<b>Office Tables</b>
<b>Estimated amount put to Tender</b>	<b>₹ 5,00,000/- (Including GST)</b>
<b>Bid Document Download Start Date</b>	<b>15/12/2020 @ 5:30 p.m</b>
<b>Clarification Start Date</b>	<b>NA</b>
<b>Clarification End Date</b>	<b>NA</b>
<b>Online Bid Submission Start Date</b>	<b>15/12/2020 @ 5:30 p.m</b>
<b>Online Bid Submission End Date</b>	<b>05/01/2021, @ 3.00 p.m.</b>
<b>Address for Submission of Tender</b>	<b><a href="https://eprocure.gov.in/">https://eprocure.gov.in/</a></b>
<b>Opening date of technical bid</b>	<b>06/01/2021 @ 3.30 p.m.</b>
<b>Contact Details of Buyer</b>	<b>Dr. Keyur Raval, 9342421444, <a href="mailto:keyurnraval@nitk.edu.in">keyurnraval@nitk.edu.in</a> 9632493401, <a href="mailto:office.crf@nitk.edu.in">office.crf@nitk.edu.in</a></b>

Sd/-  
Chairman, CRF

## **SECTION 1 A: Instructions for Online Bid Submission**

The bidders are required to submit soft copies of their bids electronically on the CPP Portal, using valid Digital Signature Certificates. The instructions given below are meant to assist the bidders in registering on the CPP Portal, prepare their bids in accordance with the requirements and submit their bids online on the CPP Portal.

More information useful for submitting online bids on the CPP Portal may be obtained at:

<https://eprocure.gov.in/eprocure/app>.

### **REGISTRATION**

- 1) Bidders are required to enroll on the e-Procurement module of the Central Public Procurement Portal (URL: <https://eprocure.gov.in/eprocure/app>) by clicking on the link “**Online bidder Enrolment**” on the CPP Portal which is free of charge.
- 2) As part of the enrolment process, the bidders will be required to choose a unique username and assign a password for their accounts.
- 3) Bidders are advised to register their valid email addresses and mobile numbers as part of the registration process. These would be used for any communication from the CPP Portal.
- 4) Upon enrolment, the bidders will be required to register their valid Digital Signature Certificate (Class II or Class III Certificates with signing key usage) issued by any Certifying Authority recognized by CCA India (e.g. Sify / nCode / eMudhra, etc.), with their profile.
- 5) Only one valid DSC should be registered by a bidder. Please note that the bidders are responsible to ensure that they do not lend their DSC's to others which may lead to misuse.
- 6) Bidder then logs in to the site through the secured log-in by entering their user ID/password and the password of the DSC / e-Token.

### **SEARCHING FOR TENDER DOCUMENTS**

- 1) There are various search options built-in the CPP Portal, to facilitate bidders to search active tenders by several parameters. These parameters could include Tender ID, Organization Name, Location, Date, Value, etc. There is also an option of advanced search for tenders, wherein the bidders may combine a number of search parameters such as Organization Name, Form of Contract, Location, Date, Other keywords, etc. to search for a tender published on the CPP Portal.
- 2) Once the bidders have selected the tenders they are interested in, they may download the required documents/tender schedules. These tenders can be moved to the respective 'My Tenders' folder. This would enable the CPP Portal to intimate the bidders through SMS / email in case there is any corrigendum issued to the tender document.
- 3) The bidder should make a note of the unique Tender ID assigned to each tender, in case they want to obtain any clarification/help from the Helpdesk.

## **PREPARATION OF BIDS**

- 1) Bidder should take into account any corrigendum published on the tender document before submitting their bids.
- 2) Please go through the tender advertisement and the tender document carefully to understand the documents required to be submitted as part of the bid. Please note the number of covers in which the bid documents have to be submitted, the number of documents - including the names and content of each of the documents that need to be submitted. Any deviations from these may lead to rejection of the bid.
- 3) Bidder, in advance, should get ready the bid documents to be submitted as indicated in the tender document/schedule and generally, they can be in PDF / XLS / RAR / DWF/JPG formats. Bid documents may be scanned with 100 dpi with the black and white option which helps in reducing the size of the scanned document.
- 4) To avoid the time and effort required in uploading the same set of standard documents which are required to be submitted as a part of every bid, a provision of uploading such standard documents (e.g. PAN card copy, annual reports, auditor certificates, etc.) has been provided to the bidders. Bidders can use the "My Space" or "Other Important Documents" area available to them to upload such documents. These documents may be directly submitted from the "My Space" area while submitting a bid, and need not be uploaded again and again. This will lead to a reduction in the time required for the bid submission process.

**Note: My Documents space is only a repository given to the Bidders to ease the uploading process. If Bidder has uploaded his Documents in My Documents space, this does not automatically ensure these Documents being part of Technical Bid.**

## **SUBMISSION OF BIDS**

1. Bidder should log into the site well in advance for bid submission so that they can upload the bid in time i.e. on or before the bid submission time. Bidder will be responsible for any delay due to other issues.
2. The bidder has to digitally sign and upload the required bid documents one by one as indicated in the tender document.
3. Bidder has to select the payment option as "offline" to pay the tender fee/ EMD (Bid Security Declaration) as applicable and enter details of the instrument.
4. Bidders are requested to note that they should necessarily submit their financial bids in the format provided and no other format is acceptable. If the price bid has been given as a standard BOQ format with the tender document, then the same is to be downloaded and to be filled by all the bidders. Bidders are required to download the BOQ file, open it and complete the white coloured (unprotected) cells with their respective financial quotes and other details (such as name of the bidder). No other cells should be changed. Once the details have been completed, the bidder should save it and submit it online, without changing the filename. If the BOQ file is found to be modified by the bidder, the bid will be rejected.
5. The server time (which is displayed on the bidders' dashboard) will be considered as the standard time for referencing the deadlines for submission of the bids by the bidders, opening of bids etc. The bidders should follow this time during bid submission.

6. All the documents being submitted by the bidders would be encrypted using PKI encryption techniques to ensure the secrecy of the data. The data entered cannot be viewed by unauthorized persons until the time of bid opening. The confidentiality of the bids is maintained using the secured Socket Layer 128-bit encryption technology. Data storage encryption of sensitive fields is done. Any bid document that is uploaded to the server is subjected to symmetric encryption using a system generated symmetric key. Further this key is subjected to asymmetric encryption using buyers/bid openers public keys. Overall, the uploaded tender documents become readable only after the tender opening by the authorized bid openers.
7. The uploaded tender documents become readable only after the tender opening by the authorized bid openers.
8. Upon the successful and timely submission of bids (i.e. after Clicking “Freeze Bid Submission” in the portal), the portal will give a successful bid submission message & a bid summary will be displayed with the bid no. and the date & time of submission of the bid with all other relevant details.
9. The bid summary has to be printed and kept as an acknowledgement of the submission of the bid. This acknowledgement may be used as an entry pass for any bid opening meetings.
10. The off-line tender shall not be accepted and no request in this regard shall be entertained whatsoever.
11. All entries in the tender should be entered in online Technical & Commercial Formats without any ambiguity.
12. Any order resulting from this e-tender shall be governed by the terms and conditions mentioned therein.
13. No deviation to the technical and commercial terms & conditions are allowed.
14. The tender inviting authority has the right to cancel this e-tender or extend the due date of receipt of the bid(s).

### **ASSISTANCE TO BIDDERS**

- 1) Any queries relating to the tender document and the terms and conditions contained therein should be addressed to the Tender Inviting Authority for a tender or the relevant contact person indicated in the tender.
- 2) Any queries relating to the process of online bid submission or queries relating to CPP Portal in general may be directed to the 24x7 CPP Portal Helpdesk.

## **SECTION 1 B: INSTRUCTION TO BIDDER (ITB)**

1. **The bid should be submitted in two covers System-Technical Bid and Financial Bid** online through portal <https://eprocure.gov.in/>:

1.1 **Envelope No.1 – Technical Bid:** The agencies should give details of their technical soundness and provide a list of customers of a previous supply of similar items to Universities, Institutes or Government Departments/ Undertakings/ public sectors with contact details. The details of the Bidder/ profile should be furnished along with the copy of all related documents. This envelope should be uploaded **online tender** (<https://eprocure.gov.in/>) and digitally signed as **“Envelope No. 1 – Technical Bid i.e. Checklist (Excel format).**

1.2. **Document to be scanned and submitted by uploading in the technical bid:**

- a) The Bidder should possess a Licence certificate for manufacture /supply of the item.
- b) List of Owner/partners of the firm and their contact numbers
- c) The Bidder should possess Income-tax PAN Number.
- d) The Bidder should possess a valid GST registration number.
- e) Catalogue of the Product with detailed product specifications.
- f) List of Service Centres
- g) List of customers with contact details.
- h) The average annual turnover should not be less than 30% of the estimated cost put to tender/Tender for the job work. The copy of the Balance sheet, Profit & Loss A/c., Trade or Manufacturing A/c for the last 3 years should be enclosed
- i) **Warranty Period Offered for the tendered item to be specified. If the Warranty period is not conforming to the schedule of requirements given in section 3 of the document, the bid is liable to be treated as non-responsive and rejected.**
- J) **Contract form given in section 5 needs to be submitted.**
- k) **EMD must be in the form of “Bid Security Declaration” declaring disqualification of his bid in case the bid is withdrawn or modified by him during the bid validity period. The format of ‘Bid Security Declaration’ is available in the Tender document. ‘Bid Security Declaration’ duly signed be uploaded while submitting the e-bid. Tenders received without the ‘Bid Security Declaration’ will be rejected (except in the case of NSIC/MSME enlisted bidders (under relevant NIC & Activity) /Startups).**

**The above documents should be furnished in the technical bid envelope.**

2. Envelope No.2 – Financial bid: The agencies should submit their financial bid as per the (.xlsx) format is given in Section 4 of the Notice Inviting Tender in this cover. The rate should be quoted in figures and upload online bid. This envelope should upload online only as “Envelope No. 2 – Financial Bid”.

Both the Envelope No. 1 and 2 should be uploaded through online portal (<https://eprocure.gov.in/>).

3 The tender will be accepted only from the **manufacturers or its authorised supplier.**

4 The Institute **reserves the right to visit the factory** before or after the issue of supply order to satisfy itself regarding the quality of production. In case of any remarks /default noted, the Company will be debarred from competing for bids in our esteemed Institute for a period of one year from the date of occurring of such breach

5 **The Financial Bid shall be in the format of Price Schedule given in Section 4. The Contract form as per format is given in section 5 shall be submitted. The incomplete or conditional tender will be rejected.**

6 Details of the item to be carried out, approximate quantity and the specifications are mentioned in “**Section 3**” appended to this Notice Inviting Tender.

7 **The item to be used is strictly according to the specification and subject to test by the Institute/concerned authorities. It must be delivered and installed in good working condition.**

8 The Institute **reserves the right to cancel or reduce the quantity** included in the schedule of requirements at any time after acceptance of the tender with a notice. The Contractor/Supplier shall have no claim to any payment of compensation or otherwise whatsoever, on account of any profit or advantage which he might have derived from the execution of the work/supply in full but he did not derive in consequence of the foreclosure of the whole or part of the works.

9 **Performance Security of 3 % of the contract value in terms of Bank Guarantee by scheduled banks shall be given by the successful bidder for the total period of Warranty.**

10 **The validity of bids:** The rate quoted should be valid for a minimum of 90 days. No claim for escalation of the rate will be considered after opening the Tender.

**11 Clarification of Tender Document:**

A prospective bidder requiring any clarification of the Tender Document may communicate to the contact person given in this notice inviting tender. The contact person will respond to any request for clarification for the Tender Document received not later than 5 working days prior to the last date for the receipt of bids

12 **Amendment of Tender document:** At any time prior to the last date for receipt of bids, Institute may for any reason, whether at its own initiative or in response to a clarification requested by a prospective bidder, modify the Tender document by an amendment.

13 **Institute may at its own discretion extend the last date for the receipt of bids.**

- 14 The bids shall be written in English language and any information printed in another language shall be accompanied by an English translation, in which case for the purpose of interpretation of the bid, the English translation shall govern.
- 15 The Institute reserves the right of accepting any bid other than the lowest or even rejecting all the bids. The decision of the Institute Purchase Committee is final in all matters of tender and purchase.
- 16 The bidder should give the following declaration while submitting the Tender.
- 17 Relaxation for Start-up, MSEs, Make in India will be as per GOI norms.
- 18 Any other details required may be obtained from the contact person (Buyer) given in the Notice Inviting Tender during the office hours.



**DECLARATION**

I/we have not tampered/modified the tender forms in any manner. In case, if the same is found to be tampered/modified, I /we understand that my/our tender will be summarily rejected and full Earnest money deposit will be forfeited and I /we are/are liable to be banned from doing business with NITK, Surathkal and/or prosecuted.

**Signature of the Bidder** : \_\_\_\_\_

**Name and Designation** : \_\_\_\_\_

**Business Address** : \_\_\_\_\_  
\_\_\_\_\_

**Place:**

**Seal of the Bidder's Firm**

**Date:**

## **SECTION 2: CONDITIONS OF CONTRACT**

1. The supplier should quote the rate for Door Delivery (FOR).
2. The Rate should be quoted in INR only.
3. No custom duty exemption certificate will be provided from the institute.
4. NITK is a DSIR recognized research organization and hence eligible for concessional / exempted rate of GST @5% (For indigenous items).
5. The rate quoted should be on a unit basis. Taxes and other charges should be quoted separately, duly considering exemptions if any.
6. Rate quoted should be inclusive of Testing, commissioning and installation of equipment and Training.
7. Payment: No advance payment will be made. Payment will be made only after the supply and installation of the item in good and satisfactory condition and receipt of performance security by the supplier.
8. Guarantee and Warranty period should be specified for the complete period conforming to section 3 of this tender document.
9. The period required for the supply and installation of the item should be specified conforming to section 3 of this tender document.
10. In case of dispute, the matter will be subject to Mangalore Jurisdiction only.

**SECTION 3: SCHEDULE OF REQUIREMENTS, SPECIFICATIONS AND ALLIED DETAILS**

[To be filled up by the Department / Center of NITK, Surathkal]

---

Item(s) Name to be procured : Office Tables

Type (Equipment / Software / Furniture / Others) : Furniture

Brief Specifications of the Item(s) : **As per Annexure "A"**  
(Attach Additional Sheet if necessary)

Quantity : 50

Any other details / requirement : Annexure-A

Warranty Period required : 1 year

Delivery Schedule expected  
after release of Purchase order  
(In Weeks) : 4 weeks (1 month)

Performance Security to be given  
by Successful Bidder after release of  
Purchase Order (in Rupees) : 3% of PO value

**SECTION 4 - PRICE BID**  
**[To be used by the bidder for submission of the bid]**

Tender Inviting Authority:

Name of Work/Goods/Services:

Contract No:

Name of the Bidder/ Bidding Firm / Company :

**PRICE SCHEDULE**

(This BOQ template must not be modified/replaced by the bidder and the same should be uploaded after filling the relevant columns, else the bidder is liable to be rejected for this tender. Bidders are allowed to enter the Bidder Name and Values only )

Number	TEXT #	NUMBER #	NUMBER #	NUMBER	NUMBER	NUMBER	NUMBER #	NUMBER #	TEXT #
Sr. No.	Item Description	Quantity	BASIC RATE in Figures To be entered by the Bidder in Rs. P	Cost	GST rate in %	GST Amount	TOTAL AMOUNT Without Taxes in Rs. P	TOTAL AMOUNT with Taxes Rs. P	TOTAL AMOUNT In Words
1									
Total in Figures									
Quoted Rate in Words									

**SECTION 5: CONTRACT FORM**

[To be provided by the bidder in the business letter head]

---

1. (Name of the Supplier's Firm) hereby abide to deliver them by the delivery schedule mentioned in section 3 tender document for the supply of the items if the purchase order is awarded.
2. The item will be supplied conforming to the specifications stated in the tender document without any defect and deviations.
3. Warranty will be given for the period mentioned in the tender document and service will be rendered to the satisfaction of NITK, Surathkal during this period.

**Signature of the Bidder** : \_\_\_\_\_

**Name and Designation** : \_\_\_\_\_

**Business Address** : \_\_\_\_\_

\_\_\_\_\_

**Place:**

**Seal of the Bidder's Firm**

**Date:**

## BANK GUARANTEE FORMAT FOR PERFORMANCE GUARANTEE BOND

(To be typed on Non-judicial stamp paper of the value of Indian Rupees of One Hundred)

(TO BE ESTABLISHED THROUGH ANY OF THE NATIONAL BANKS (WHETHER SITUATED AT MANGALORE OR OUTSTATION) WITH A CLAUSE TO ENFORCE THE SAME ON THEIR LOCAL BRANCH AT MANGALORE OR ANY SCHEDULED BANK (OTHER THAN NATIONALISED BANK) SITUATED AT MANGALORE. BONDS ISSUED BY CO-OPERATIVE BANKS ARE NOT ACCEPTED.)

To,  
Director,  
National Institute of Technology Karnataka,  
Srinivasnagar P.O., Surathkal  
Mangalore – 575025

### LETTER OF GUARANTEE

WHEREAS National Institute of Technology Karnataka (Buyer) has invited Tenders vide Tender No..... Dt. .... for purchase of ..... AND WHEREAS the said tender document requires that any eligible successful tenderer (seller) wishing to supply the equipment/machinery, etc. in response thereto shall establish an irrevocable Performance Guarantee Bond in favour of “**Director, National Institute of Technology Karnataka, Surathkal**” in the form of Bank Guarantee for Rs ..... (**3% (Three percent) of the purchase value**) and valid till **one year or up to warranty period whichever is later** from the date of issue of Performance Guarantee Bond may be submitted within 30 (Thirty) days from the date of Order Acknowledgement as a successful bidder.

NOW THIS BANK HEREBY GUARANTEES that in the event of the said tenderer (seller) failing to abide by any of the conditions referred in tender document/purchase order/performance of the equipment/machinery, etc. this Bank shall pay to National Institute of Technology Karnataka, Surathkal on demand and without protest or demur Rs ..... (Rupees.....).

This Bank further agrees that the decision of National Institute of Technology Karnataka, Surathkal (Buyer) as to whether the said Tenderer (Seller) has committed a breach of any of the conditions referred in the tender document/purchase order shall be final and binding.

We, ..... (name of the Bank & branch) hereby further agree that the Guarantee herein contained shall not be affected by any change in the constitution of the Tenderer (Seller) and/ or National Institute of Technology Karnataka, Surathkal (Buyer).

#### **Notwithstanding anything contained herein:**

1. Our liability under this Bank Guarantee shall not exceed Rs. .... (Indian Rupees ..... only).
  2. This Bank Guarantee shall be valid up to .....(date) and
  3. We are liable to pay the guaranteed amount or any part thereof under this bank guarantee only and only if National Institute of Technology Karnataka (NITK) Surathkal serve upon us a written claim or demand on or before.....(date).
- This Bank further agrees that the claims if any, against this Bank Guarantee, shall be enforceable at our branch office at ..... situated at ..... (Address of local branch).

Yours truly,  
Signature and seal of the guarantor:  
Name of Bank & Address:  
Date:

**Instruction to Bank:** Bank should note that on expiry of Bond Period, the Original Bond will not be returned to the Bank. The bank is requested to take appropriate necessary action on or after expiry of bond period.

Form of "Bid Security Declaration" - To be submitted in the **Letterhead of the Bidder**

**"BID SECURITY DECLARATION"**

To:  
**The Director,  
National Institute of Technology Karnataka, Surathkal.  
Post Srinivasnagar, Mangaluru – 575025.**

Sir,

Sub.: Submission of Bid Security/ EMD Declaration – Reg.

Ref.: Tenders invited for "-----" vide NIT No. -----

I/ We declare that:

1. I/ We understand that according to the tender document, bids must be accompanied by EMD or a Bid Security Declaration. Accordingly, I/ We have opted for submitting this Bid Security Declaration.
2. I/ We declare that I / We will not withdraw our bid during the Bid validity period or make any modifications to my/ our bid.
3. I/ We understand that if I/ we withdraw my/ our bid or modify the bid, I/ we will be automatically suspended from being eligible for bidding and also will be debarred from competing for bids in your esteemed Institute for a period of one year from the date of occurring of such breach.
4. / We understand that if I/ We fail to furnish the Performance Guarantee before the deadline specified in the LoA / Lol, my/ our bid will be automatically cancelled and I/ We will also be debarred from competing for bids in your esteemed Institute for a period of one year from the date of occurring of such breach.
5. I/ We further understand that if I/ We fail to sign the contract in case the work is awarded to me/ us or fail to furnish the Performance Guarantee, my/ our bid will be automatically cancelled and I/ We will also be debarred from competing for bids in your esteemed Institute for a period of one year from the date of occurring of such breach.
6. I/ We understand that this Bid Security Declaration will automatically expire if we are not the successful bidder/ upon the expiry of bid validity period.
7. I/ we declare that I am/ we are authorized to sign this declaration.

Duly signed this Declaration on this day - - 2020 in the presence of following witnesses:

**Signature of the Bidder with seal**

In the presence of:  
Signature of witness:  
Signature:

In the presence of:  
Signature of witness:  
Signature:

Postal address:

Postal address:

**Detailed Technical Specifications**

**Office Steel Tables Specification:**

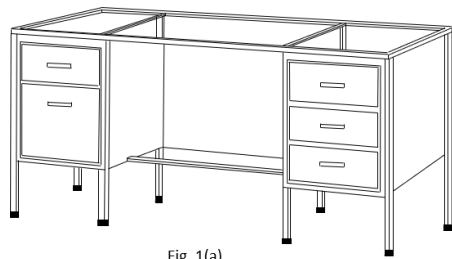

Fig. 1(a)

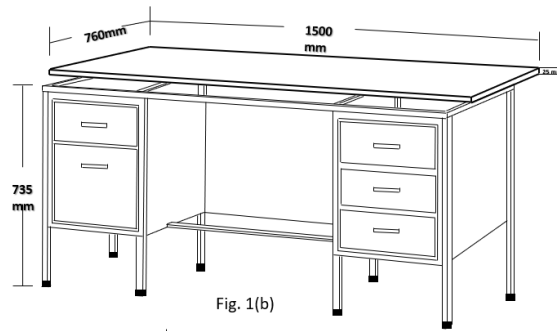

Fig. 1(b)

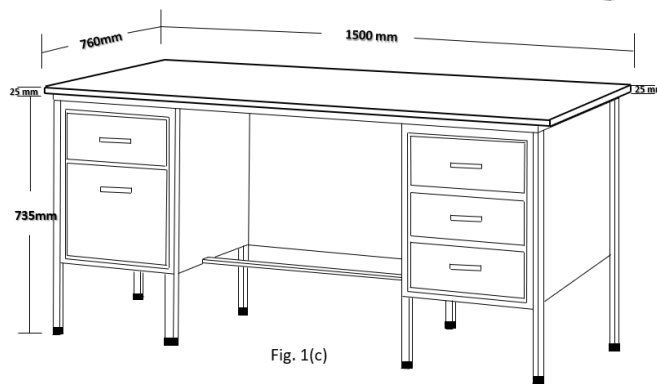

Fig. 1(c)



Fig. 2



- Both side storage unit with locking facility, 3 drawer unit, 1 box, and 1 file drawer unit with locking facility
- Type of Storage Units : Refer Fig 1a, 1b, 1c & Fig. 2.
- Handles Material : Corrosion Resistance Metal.
- Tabletop frame material : As per Fig. 1(a), 18 gauge mild steel material.
- Total numbers of Legs : 8 nos, 18 gauge mild steel material.
- Table Top frames and Table legs must be fabricated as per the given Drawing Fig 1(a)., Fig 1(b), Fig 1(c)
- Table Top Material : 25 mm thick Plywood or Multiplex table Top with sunmica finishing.
- Table Top Length : 1500 millimeter
- Table Top Width : 760 millimeter
- Table Height : 760 millimeter
- Loading capacity of tabletop: 500 kg
- Foot Rest : Yes, comfortable for long working hours.
- Shoe Material : Standard shoes/bushes.
- Warranty : 3 Years
- Colour & finish : As per Fig. 2.

The table will be used to keep the high-end research instruments, so it is required to match all the specifications. The required table details are indicated in Fig. 1 (a), Fig. 1(b) & Fig. 1(c). The Bids which are meeting all the specifications will be accepted for further process.